

ATN

INTERNATIONAL

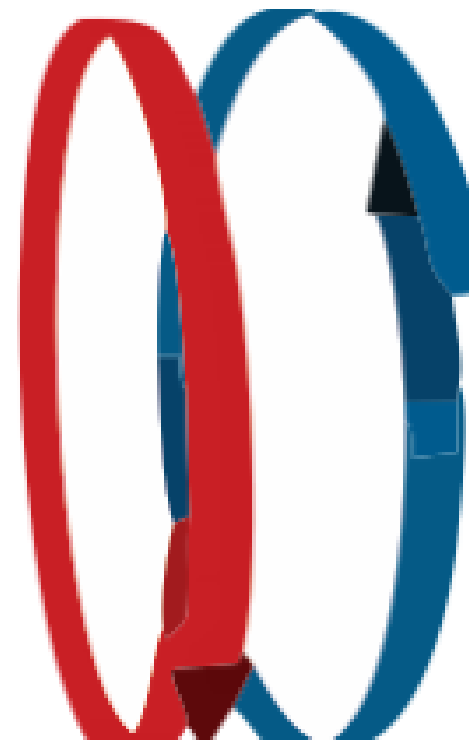

Информация о компании

- Проектирование и производство в Германии
- Компания с почти 30-летним опытом
- Система менеджмента качества - DIN EN ISO 9001:2015
- Сертифицировано в соответствии с Директивой по оборудованию, работающему под давлением 2014/68/EU
- Производство по стандартам DIN, JUS, EN, ASME, Nace, Norsok
- Опыт работы с европейскими промышленными компаниями

- ()

- BASF
- Covestro / Bayer
- Kar Kunz
- Petrotank
- Protego
- Skytanking
- WILLO
- Siemens
- Arcelor Mittal
- SMS Siemag
- Shell
- INEOS
- Dr. Esterer
- Bosch Rexroth
- Titan Aviation
- ThyssenKrupp

Технические данные - вращающиеся соединения:

Вращающиеся соединения ATN обеспечивают трубопроводным системам свободную и в то же время безопасную транспортировку жидкостей и газов

Номинальные размеры от DN25 (1") до DN1200 (48")

Различные формы в зависимости от количества осей вращения

Температурный диапазон от -60°C до $+300^{\circ}\text{C}$
(специальные конструкции до $+600^{\circ}\text{C}$)

Давление: от вакуума до 420 bar

Тип соединения: сварка, фланец или резьба

Материалы: Конструкционная и легированная сталь, Aluminium, Duplex, Super Duplex, Hastelloy

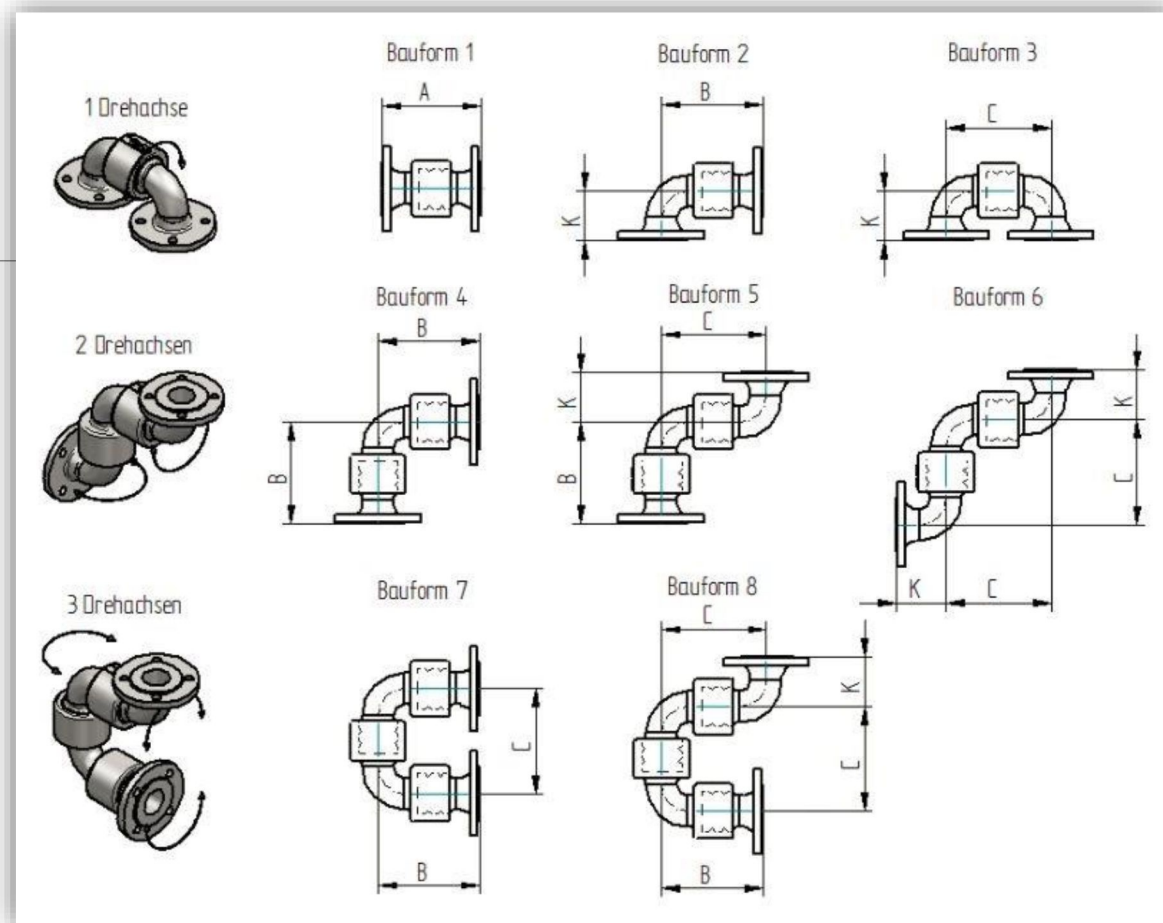

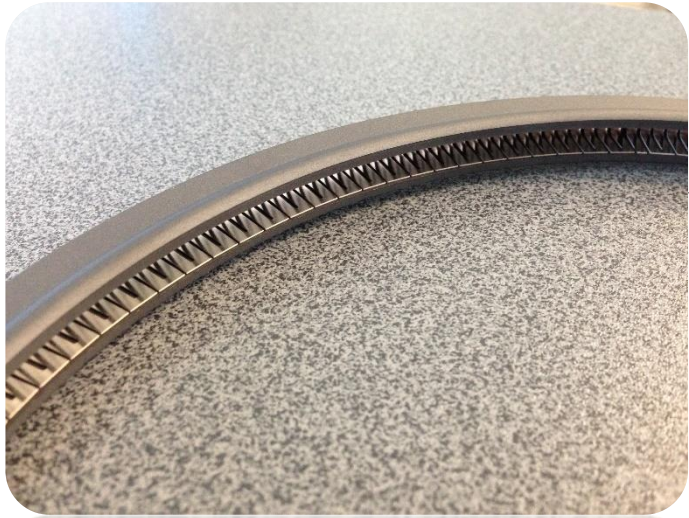

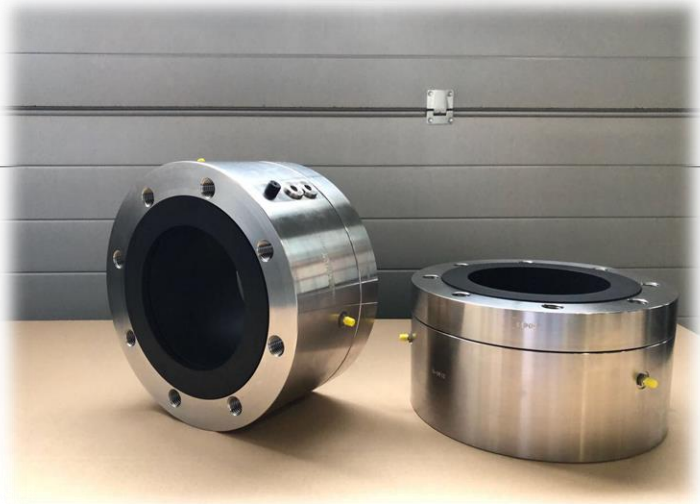





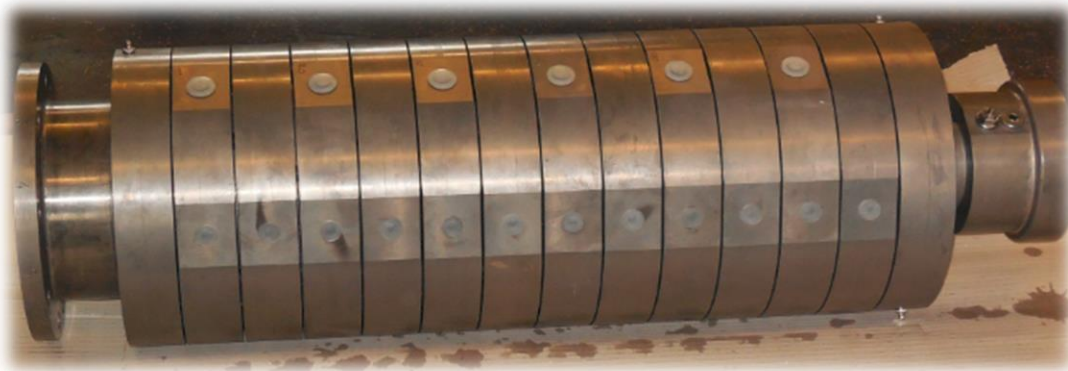
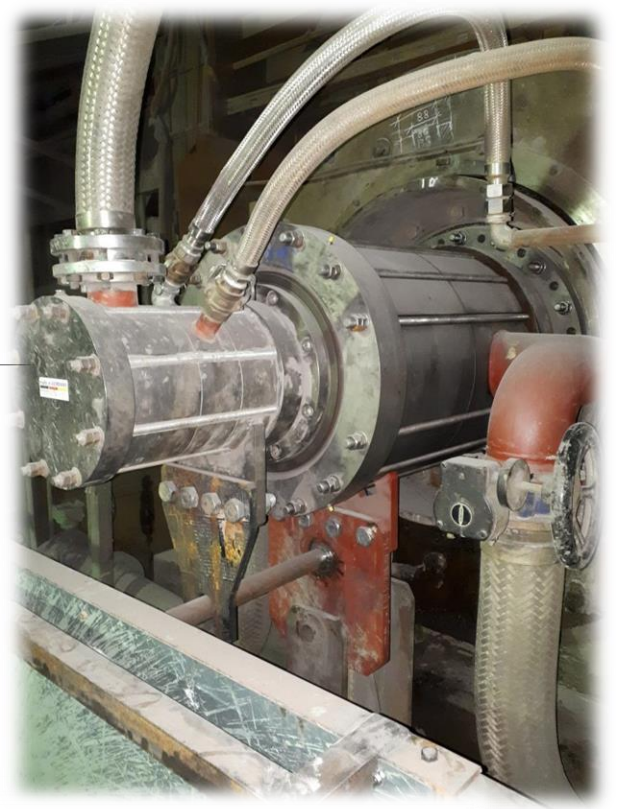

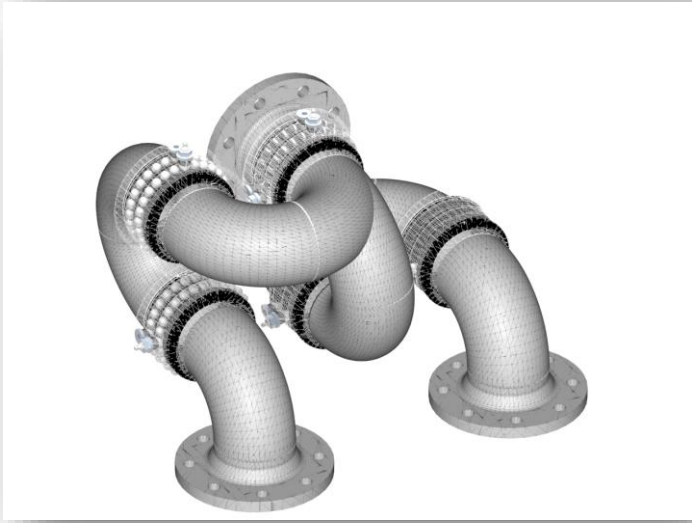
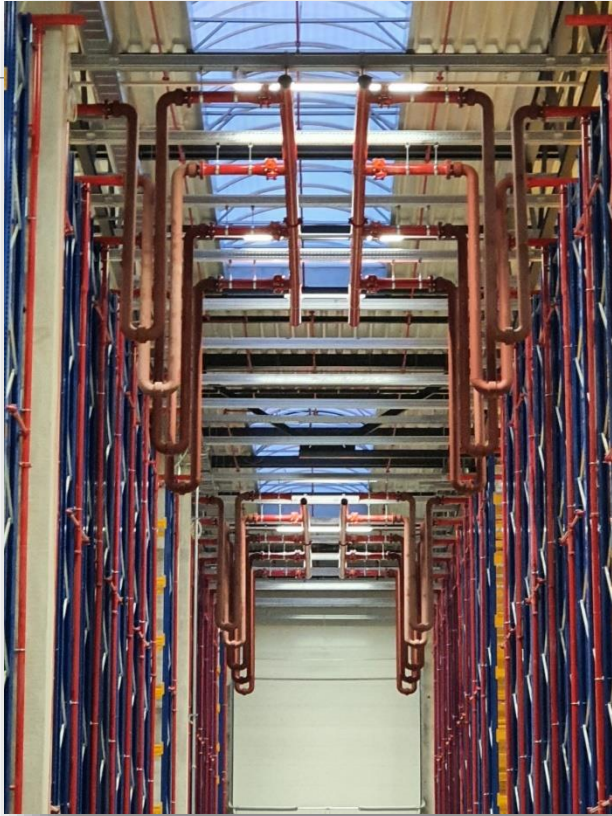

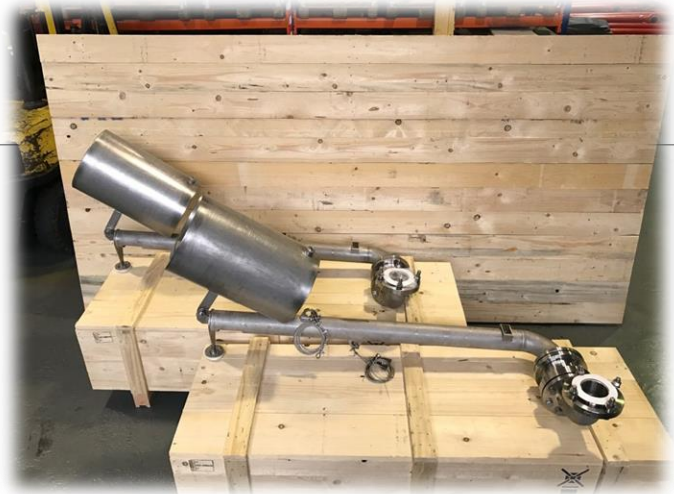

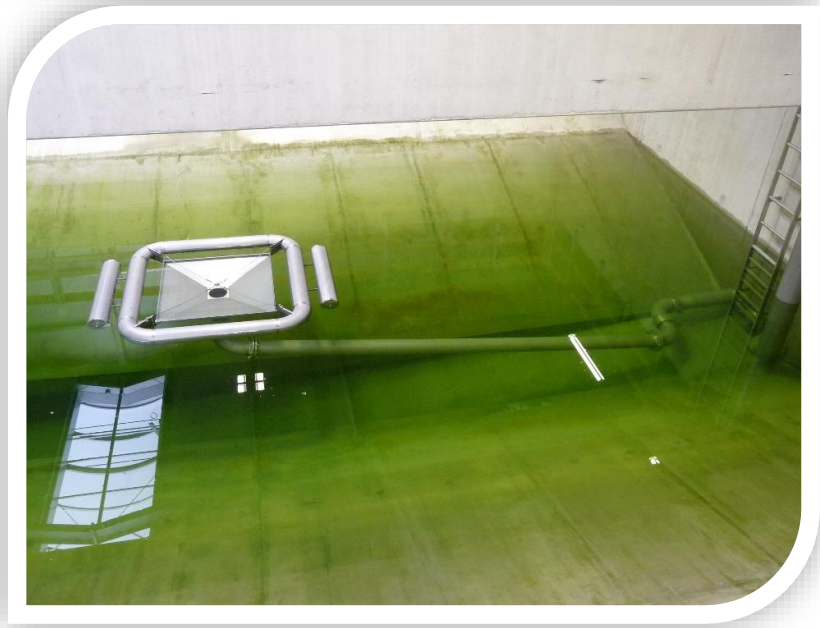
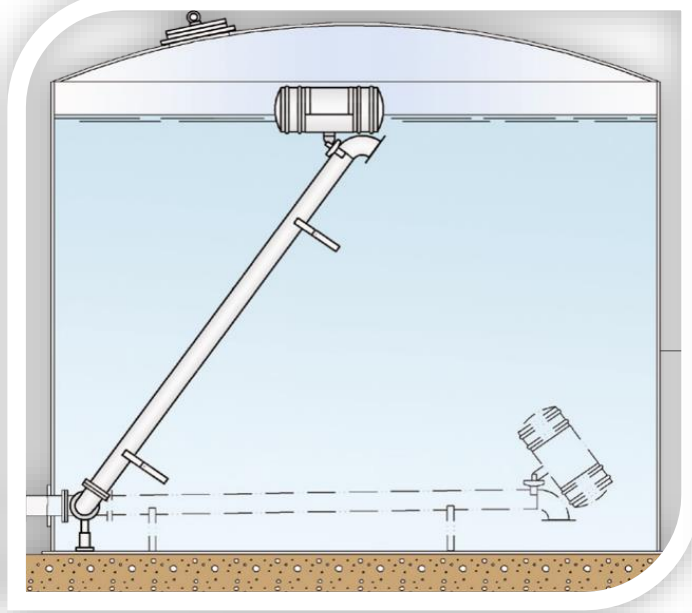



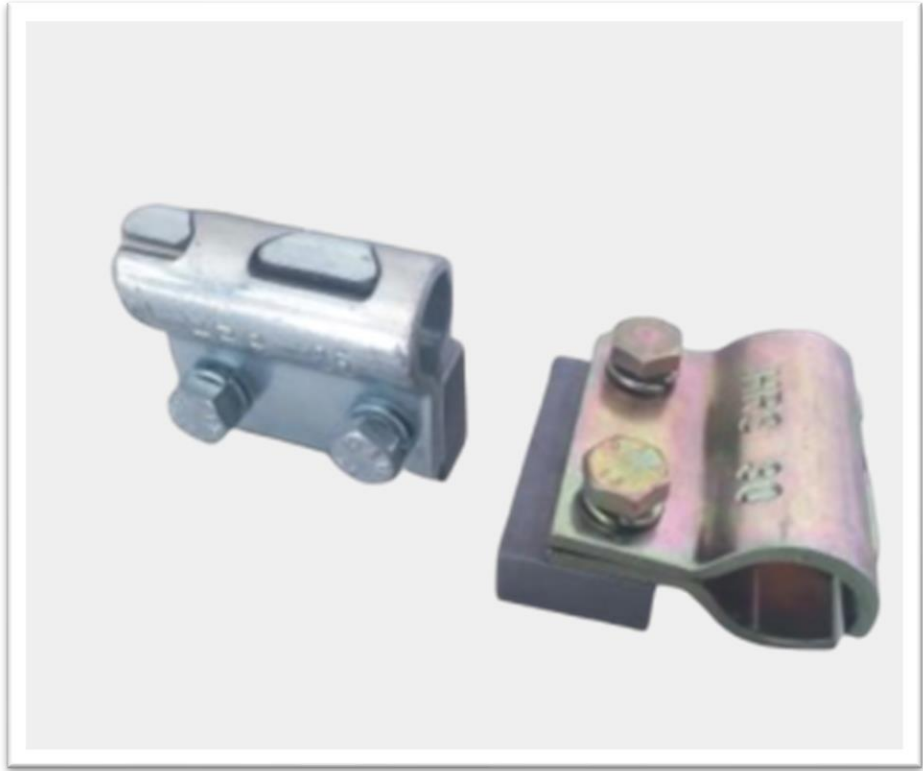

ATN

INTERNATIONAL

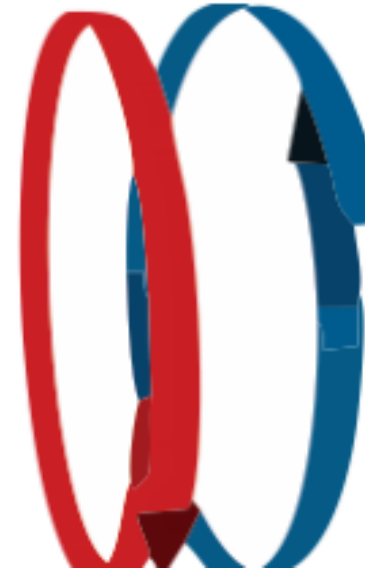

ATN International

Politova 1, 11000 Belgrade, Serbia

Contact +381 11 670 68 74

+381 67 7 471 700

+381 67 7 471 701

Email: office@atn-inter.com

Web: atn-inter.com

